



SRI RAAJA RAAJAN

COLLEGE OF ENGINEERING AND TECHNOLOGY

**(APPROVED BY AICTE, NEW DELHI & AFFILIATED TO ANNA
UNIVERSITY, CHENNAI.)**

146/14B1, Amaravathi Village, Amaravathiputhur Post,

Karaikudi -630301, Sivagangai Dt, Tamilnadu

**Website: www.srirajaraajan.in. E - Mail: srrcet2010@gmail.com. Ph:
04565-234230**

Footstep Power Generation Using Piezoelectric Sensor

ABSTRACT:

Man has needed and used energy at an increasing rate for the sustenance and well-being since time immemorial. Due to this a lot of energy resources have been exhausted and wasted. Proposal for the utilization of waste energy of foot power with human locomotion is very much relevant and important for highly populated countries like India where the railway station, temples etc., are overcrowded all round the clock. When the flooring is engineered with piezo electric technology, the electrical energy produced by the pressure is captured by floor sensors and converted to an electrical charge by piezo transducers, then stored and used as a power source. And this power source has many applications as in agriculture, home application and street lighting and as energy source for sensors in remote locations. This paper is all about generating electricity when people walk on the Floor. Think about the forces you exert which is wasted when a person walks. The idea is to convert the weight energy to electrical energy The Power generating floor intends to translate the kinetic energy to the electrical power. Energy Crisis is the main issue of world these days. The motto of this research work is to face this crisis somehow. Though it won't meet the requirement of electricity but as a matter of fact if we are able to design a power generating floor that can produce 100W on just 12 steps, then for 120 steps we can produce 1000 Watt and if we install such type of 100 floors with this system then it can produce 1MegaWatt. Which itself is an achievement to make it significant.

INTRODUCTION

Day by day, the population of the country increased and the requirement of the power is also increased. At the same time the wastage of energy also increased in many ways. So reforming this energy back to usable form is the major solution. As technology is developed and the use of gadgets, electronic devices also increased. Power generation using conservative methods becoming deficient. There is a necessity arises for a different power generation method. At the same time the energy is wasted due to human locomotion and many ways. To overcome this problem, the energy wastage can be converted to usable form using the piezoelectric sensor. This sensor converts the pressure on it to a voltage. So by using this energy saving method that is the footstep power generation system we are generating power. This project is used to generate voltage using footstep force. The proposed system works as a medium to generate power using force. This project is very useful in public places like bus stands, theaters, railway stations, shopping malls, etc. So, these systems are placed in public places where people walk and they have to travel on this system to get through the entrance or exists. Then, these systems may generate voltage on each and every step of a foot. For this purpose, piezoelectric sensor is used in order to measure force, pressure and acceleration by its change into electric signals. This system uses voltmeter for measuring output, LED lights, weight measurement system and a battery for better demonstration of the system. In another way, we are also saving natural energy resource.

NEED OF SYSTEM

The Utilization of the Waste Energy foot Power With human motion is very important and highly populated countries. India and china where the roads railway stations, temples Etc, Are all over crowded and millions of people move around the clock.

PIEZOELECTRIC SENSOR

A piezoelectric sensor is a device that uses the piezoelectric effect to measure changes in pressure, acceleration, temperature, strain, or force by converting them to an electrical charge. When a force is applied to a piezoelectric material, an electric charge is generated across the faces of the crystal. This can be measured as a voltage proportional to the pressure (see diagram to the right). A given static force results in a corresponding charge across the sensor. Flex motions, touch, vibrations, and shock measurement all use piezoelectric sensors. They are used in sectors such as healthcare, aerospace, consumer electronics, and nuclear instrumentation. A piezoelectric sensor converts physical parameters - for example, acceleration, strain or pressure into an electrical charge which can then be measured. They are highly sensitive and very small in size making them well suited to everyday objects.



TREE DIAGRAM

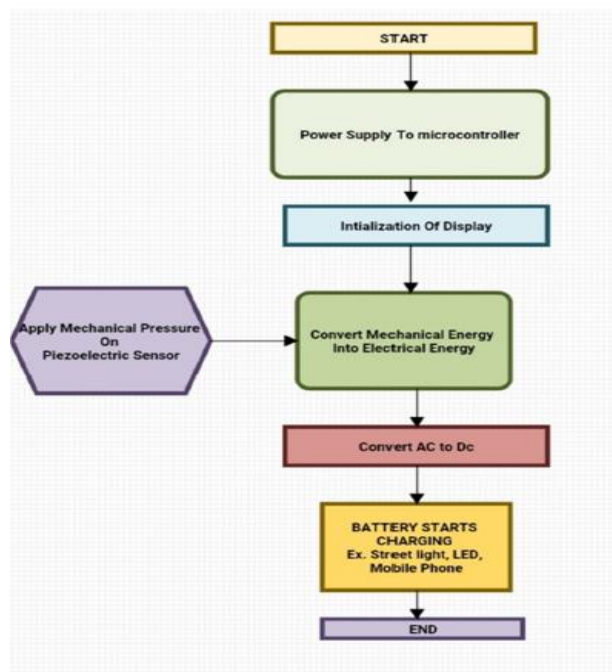

WORKING

The main components of the system include piezoelectric sensors, voltage boosters, voltage regulator, PIC microcontroller, battery, LCD display, LDR and a socket for mobile charging. Here in this system, at first, the output from an array of piezo electric sensors is fed into voltage booster. In the system, two voltage boosters are used to boost the voltage to get the desired output. The output from piezoelectric sensor is in the range of 3 V to 4 V. It has to be boosted to a range of 9 V to 12V with the help of voltage boosters. A constant output voltage irrespective of fluctuations will be maintained by a voltage regulator. This regulated voltage is stored in the battery and is fed to the microcontroller. The LCD which is interfaced with the microcontroller in turn displays the amount of charge stored by the battery. In this system the power generated has been used for two applications such as lighting a street light and charging a mobile phone. A LDR is used to indicate the street light application. A buzzer is used to alert when the battery voltage falls below the required voltage for charging the microcontroller. For PIC microcontroller 5 V is required for its working. The mobile charging socket also requires 5 V for its operation. A pull down resistor is used in the socket to pull down the voltage to 5 V. The power is generated by simply walking over a step. The system does not need any fuel input for its functioning this is a non-conventional system in which battery is used to store the generated power. Even though the force is used to generate power, the system is applicable to particular places. Mechanical moving parts used in the system are large there by increasing the cost. The power generation using footsteps can be implemented effectively in schools, colleges, cinema theaters, shopping complexes, temples and many other buildings.

MICROCONTROLLER UNIT

The main controlling unit of the entire system is a microcontroller. The input of the microcontroller is the output from the voltage generator. For the project PIC8F4520 is used The filter used removes the AC components from the output voltage of the sensor. It acts like a short circuit for ac voltage and open circuit for dc voltage. A LCD display is interfaced with the microcontroller.

VOLTAGE BOOSTER

It is a DC to DC converter and output voltage greater than the input voltage. The device has at least two semiconductors and one energy storage element. It is a class of switched mode power supply.

MOBILE CHARGING

Designed the external circuit connection as per the block diagram by using PIC16F677. The input of the PIC is given from the piezo electric crystal. The output from 15th pin of the PIC is given as a socket input. The output from the socket is 5v which can be used for a mobile charging.

FUTURE SCOPE

The piezoelectric crystals have been started better use with the positive result. In China and Japan, maximum public movement is observed in railway station, airports and shopping malls. Hence this place can be used for piezoelectric crystals for generation of electric power. Apart from all the above places attempts are made to develop energy from our daily life by installing piezoelectric in shoes thus in each step piezoelectric crystal can be compressed which can turn enough power to charge a cell phone, mp3 player etc. Through this we can generate electric power and use that for small electronic gadgets.

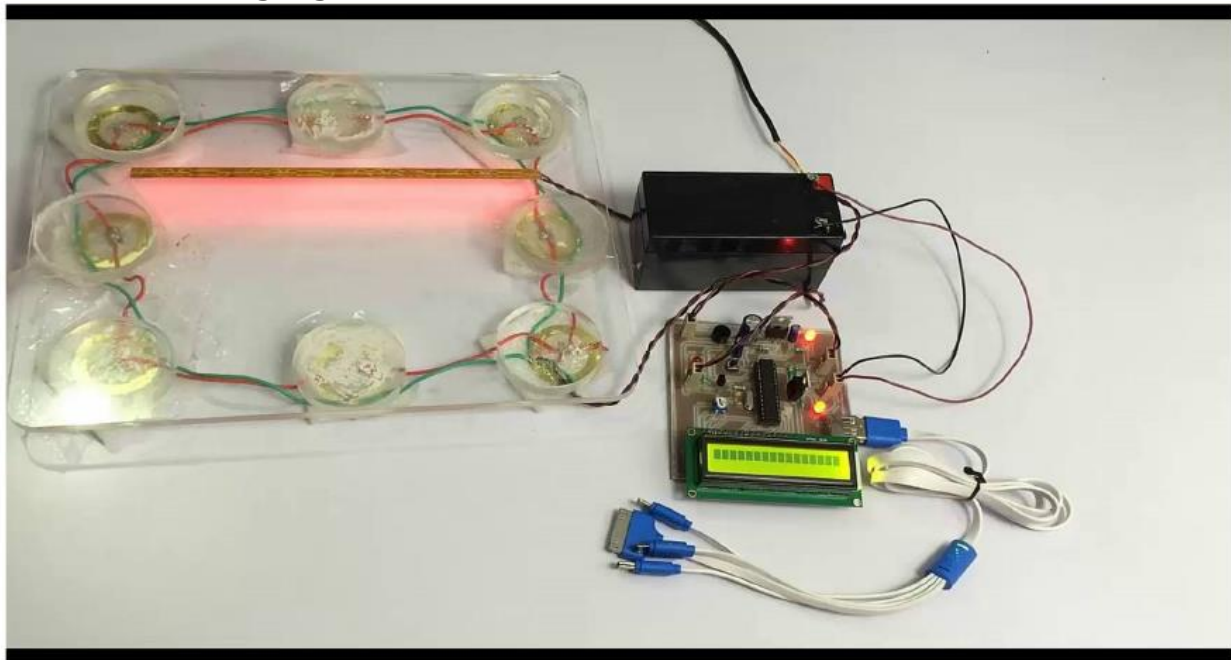

USE OF PROPOSED SYSTEM

From time immemorial, human powered transport has been in existence in forms like running, walking etc. machines led to the enhanced use of human power in an efficient manner. Energy of human locomotion can be converted to electrical energy with the help of promising technologies. In this system, there is a sub flooring block of piezo electric crystals, which imparts an electrical current when people walk across it. The pressure polarizes the crystal there by separating the centers of positive and negative charges. Application of voltage on the crystal produces mechanical distortion of the material. Direct piezo electric effect, which is the phenomenon of generation of voltage under mechanical stress is employed in the system. The application of mechanical stress produces an electric polarization which is proportional to the stress. If the crystal is short circuited, flow of charge can be observed during loading

PROBLEM FORMULATION & SOLVING

- A. As technology is developed use of electronics equipment also increased
- B. Conventional methods of power generation becoming insufficient.
- C. It introduced a new problem, lack of power.
- D. There is a need arises for an alternative power generation method
- E. At the same time energy is wasted in many form and one of them is due to the human locomotion

ADVANTAGES

- 1) Power generation is simply walking on step
- 2) No need fuel input
- 3) There is a non-conventional system
- 4) No moving parts long service life
- 5) Compact yet highly sensitivity
- 6) Self generating no external power required

CONCLUSION

In this project, we are generating electrical power as non-conventional method by simply walking or running on the foot step. Nonconventional energy system is very essential at this time to our nation. Non-conventional energy using foot step is converting mechanical energy into the electrical energy. By using this energy conservation theorem and Piezo sensor we are proposing a new method for power generation. Proposal for the utilization of waste energy of foot power with human locomotion is very much relevant and important for highly populated countries like India and China where the roads, railway stations, bus stands, temples, etc. are all over crowded and millions of people move around the clock



SRI RAAJA RAAJAN

COLLEGE OF ENGINEERING AND TECHNOLOGY

**(APPROVED BY AICTE, NEW DELHI & AFFILIATED TO ANNA
UNIVERSITY, CHENNAI.)**

146/14B1, Amaravathi Village, Amaravathiputhur Post,

Karaikudi -630301, Sivagangai Dt, Tamilnadu

**Website: www.srirajaraajan.in. E - Mail: srrcet2010@gmail.com. Ph:
04565-234230**

IOT Based Smart Energy Meter

ABSTRACT:

Due to rapid increase in human population and the human's dependency towards electrical energy, the demand for electricity has increased many folds, causing deficit of electrical energy during peak hours. In order to cope up with the energy challenges, it is necessary to modernize the electrical system. Internet of Things (IoT) technology can be employed to energy consumption and distribution in different scenarios. This paper mainly focuses on automatic billing, power card facility, theft detection, power optimization and providing the relevant energy consumption information to user. IOT based smart energy meter system basically consists of three major components namely controller, Wi-Fi and Theft detection device. Whenever there is any theft or fault, the theft detector sensor detects the error and responds accordingly. The controller plays a vital role in keeping all the components in working state. In this system energy meters are connected to the internet i.e., using IoT concept, eliminates the human intervention in electricity maintenance. In the proposed work, IoT based meter reading system is designed to continuously monitor the meter reading and service provider can disconnect the power source whenever the consumer does not pay the monthly bill and also it eliminates the human intervention, delivers effective meter reading, prevent the billing mistakes..

INTRODUCTION

At present, Electricity is the essential commodity in the world for human life today. Every home, offices, companies, industries requires electricity connection for their functioning. Due to rapid increase in human population and the human's dependency towards electrical energy, the demand for electricity has increased many folds, causing deficit of electrical energy during peak hours. In order to cope up with the energy challenges, it is necessary to modernize the electrical system. Internet of Things (IoT) technology can be employed to energy consumption and distribution in different scenarios. Latest development in IoT and digital technology, the concept of smart city is becoming smarter compared to earlier years. Therefore it is necessary to switch over to innovative and better alternatives such as smart grid, smart metering and zero energy building that will assist to minimize reliance on these assets by minimizing energy consumption and improving usage of renewable energies. This will in turn increase the efficiency of power and energy manages system .Accurate metering, detection of theft and implementation of proper tariff and billing system would manage the consumption of electrical energy. Collecting meter reading is one of the most difficult procedures in billing. The traditional electrical energy meter data collection is such that a person from the utility provider visits the consumer sites periodically to note the meter reading. This procedure has lot of drawbacks such as, it is time consuming, tiresome, requires more human resource, human error and even corruption is probable. The process may be interrupted due to bad weather conditions, also if the consumer is not available, the billing will be pending and human operator needs to revisit. India is facing energy deficit during peak hours. Low voltage during peak hours has been reported as a major power quality issue. Load shedding is a common power management practice followed by the utility providers. Energy conservation has great significance in this scenario of increasing electrical energy demand. The present system of energy billing is error prone, time consuming and laborious. Errors get introduced at every stage of energy billing like errors with electro-mechanical meters, human errors while noting down the meter reading. These errors can be overcome by using the smart energy meter. The main objective of the proposed work is to develop a smart energy meter. The Arduino takes the pulse from the energy meter, calculate

units and displays the reading on the LCD. The reading is stored in built in EEPROM so, in case of power failures it continues the computation. The reading of the energy meter is also sent to the cell phone of the user in the form of a message through Wi-Fi modem.

The proto type system is powered by external power supply that takes the ac power and converts it into dc power and is fed to Arduino and Wi Fi.

This paper mainly focuses on automatic billing, power card facility, theft detection, power optimization and providing the relevant energy consumption information to user. Here the user can monitor the energy consumption units from a web page by providing device IP address. Theft detection unit connected to energy meter will notify company side when meter tampering and theft detection occurs in energy meter through PLC modem and theft detected will be displayed on the terminal window. In this system energy meters are connected to the internet i.e., IoT concept and it eliminates the human intervention in electricity maintenance. This paper is presented in six sections including introduction section. Section II presents the details of proposed prototype IoT based smart energy meter system.

Title 1: Smart sensory energy metering.

Introduction:

SSEM (Smart Sensory Energy Metering) is an electronic device that records consumption of electric energy and allows customers to program how and when their home uses energy.

Title 2: IOT Based Smart Energy Meter for Efficient Energy Utilization in Smart Grid.

Introduction:

Smart grid plays an important role in our current society and in our networks. Smart meters play a vital role. Smart meter provides immediate monitoring of reliable status, automatic information collection, user interaction and energy control. It also provides a double flow of information between consumers and suppliers, provides better control and efficiency. It also provides real-time consumption information and provides power control. As long as the

customer's maximum load demand exceeds the maximum value, the electricity supply to customers will be separated with the help of an intelligent power meter. In an ideal environment with normal workload conditions, the smart meter has a service life of 5 to 6 years.

In project, the use age of the smart meter with IOT technology is introduced. The IOT-based power meter system consists mainly of three main parts, which are remote control, Wi-Fi and theft detection part. When there is an error or theft, the theft detection sensor detects the error response and the circuit according to the information it receives. The console plays a key role in the system to ensure that all components work well. Therefore, Internet of things can improve the performance and efficiency of the smart grid mainly in the three phases.

Title 3: Implementation of Smart Meter Working as IEEE1888-6LoWPAN Gateway for the Building Energy Management Systems.

Introduction:

When building the power management system, Smart Meter (SM) plays an important role in helping users feel active and determine energy consumption. As a result, multiple efforts have been made to improve the function of this device in order to contribute to the reduction of energy consumption towards a green economy and sustainable development. In addition to SM, other protocols have been developed to achieve intelligent, convenient and safe management and control between buildings or building blocks. With the growing growth of devices connected to the Internet, the Internet of things, the integration of millions of devices into the Internet IPv4 is not the best option. Therefore, IPv6 is designed to solve this problem. IPv6 allows more Internet based devices. IPv6 is more complex than IPv4; therefore, devices usually consume more energy. Based on previous concerns, the low power IPv6 protocol was developed for the wireless personal area network to reduce consumption.

PROPOSED METHODOLOGY

Our proposed system uses the Arduino UNO board, Wi-Fi module and a LCD display. The Wi-Fi module is the main component in the IOT operation. The Arduino UNO board is connected to a sensor which will sense the meter readings and the readings are then processed and are updated over the Wi-Fi through the Wi-Fi module. The readings are updated over the webpage which

can be easily accessed by the users. This allows the user to easily check the energy usage by using a simple web application. Thus this system allows the users to effectively monitor the electric meter readings and check the billing online with ease

HARDWARE DETAILS

In this section hardware details are described, first design module is explained then brief description about each hardware components are given one after the other in the following section.

Design Model

In the prototype system the power utility maintains a server and each consumer are provided an energy meter. The server, power sim meters and Wi-Fi module are used to communicate with each other using Wi-Fi network. Fig 2 shows prototype power sim energy management system. The energy meter consists of a microcontroller (ATmega328), energy measuring chip (AAE7751), Current transformer, potential transformer, LCD display and a relay. The energy consumption by counting the output pulses of the EM chip on an interrupt basis. The Microcontroller uses AT command set to communicate with the Wi-Fi module. The Embedded C programming language has been used to program the microcontroller and to connect the server respectively.

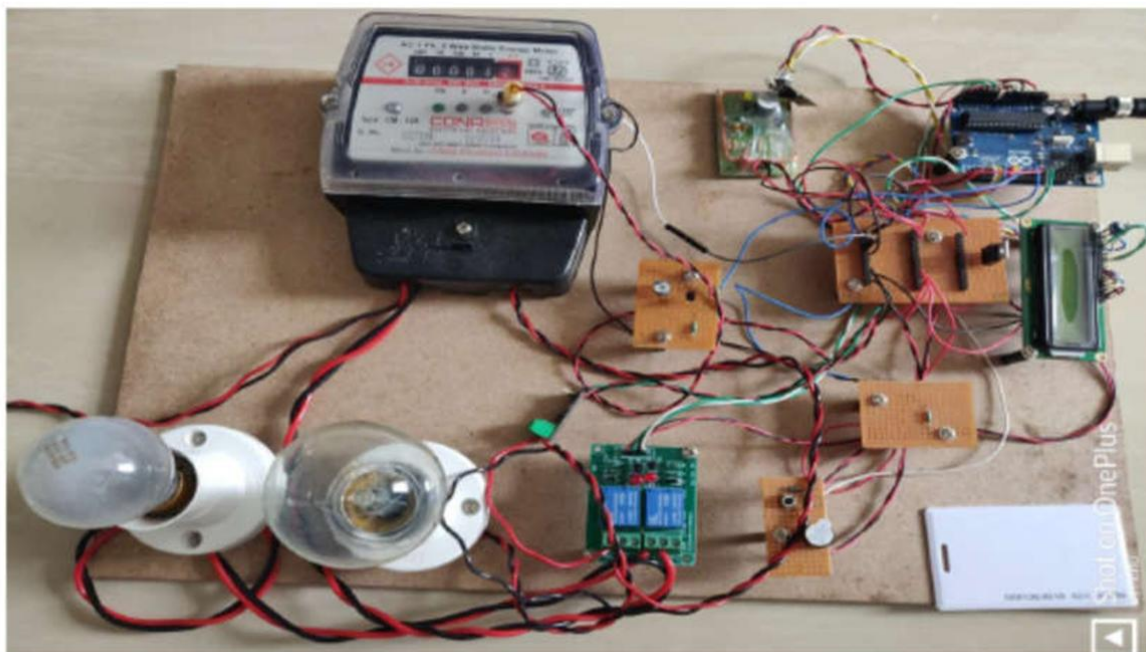

Digital Electronic Energy Meters: Digital signal processor or high performance microcontrollers are used in digital electric meters. Similar to the Analog meters, voltage and current transducers are connected to a high resolution ADC. Once it converts Analog signals to digital samples, voltage and current samples are multiplied and integrated by digital circuits to measure the energy consumed. Microcontroller also calculates phase angle between voltage and current, so that it also measures and indicates reactive power. It is programmed in such a way that it calculates energy according to the tariff and other parameters like power factor, maximum demand, etc. and stores all these values in a non-volatile memory EEPROM. It contains real time clock (RTC) for calculating time for power integration, maximum demand calculations and also date and time stamps for particular parameters. Further it interacts with liquid crystal display (LCD), communication devices and other meter outputs. Battery is provided for RTC and other significant peripherals for backup power.

Arduino

Current Arduino boards are programmed via Universal Serial Bus (USB), implemented using USB-to-serial adapter chips such as the FTDI FT232 is shown in figure 3. Some boards, such as later-model Uno boards, substitute the FTDI chip with a separate AVR chip containing USB-to-serial firmware, which is reprogrammable via its own ICSP header. Other variants, such as the Arduino Mini and the unofficial Boarding, use a detachable USB-to-serial adapter board or cable, Bluetooth or other methods, when used with traditional microcontroller tools instead of the Arduino IDE, standard AVR in-system programming (ISP) programming issued.



LCD display

A liquid-crystal display (LCD) shown in figure 4, is a flat-panel display or other optical device that uses the light modulating properties of liquid crystals. Liquid crystals do not emit light directly, instead using a backlight or reflector to produce images in colour or monochrome. LCDs are available to display arbitrary images (as in a general-purpose computer display) or fixed images with low information content, which can be displayed or hidden, such as pre-set words, digits, and 7-segment displays, as in a digital clock. They use the same basic technology, except that arbitrary images are made up of a large number of small pixels, while other displays have larger elements.

Regulated Power Supply

Today almost every electronic device needs a dc supply for its smooth operation and they need to be operated within certain power supply limits. This required dc voltage or dc supply is derived from single phase ac mains. A regulated power supply can convert unregulated an ac (alternating electric current or voltage) to a constant dc (direct electric current or voltage). A regulated power supply is used to ensure that the output remains constant even if the input changes. A regulated DC power supply is also called as a linear power supply; it is an embedded circuit and consists of various blocks. The regulated power supply will accept an ac input and give a constant dc output. Figure5 shows a typical regulated dc power supply.

Wi-Fi Module (ESP8266)

ESP8266 is Wi-Fi enabled system on chip (SoC) module developed by Espressif system is shown in figure 7. It is mostly used for development of IoT (Internet of Things) embedded applications. It employs a 32-bit RISC CPU based on the Tensilica Xtensa L106 running at 80 MHz (or over clocked to 160 MHz). It has a 64 KB boot ROM, 64KB instruction RAM and 96 KB data RAM. External flash memory can be accessed through SPI. ESP8266 module is low cost standalone wireless transceiver that can be used for end- point IOT developments. To communicate with the ESP8266 module, microcontroller needs to use set of AT commands. Microcontroller communicates with ESP8266-01 module using UART having specified Baud rate.

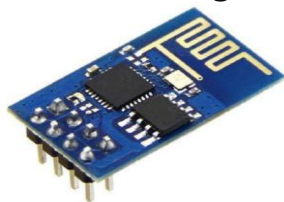

The Project has achieved following objectives:-

1. Easy of accessing information for consumer from energy meter through IoT.
2. Theft detection at consumer end in real time.
3. LCD displays energy consumption units and temperature.
4. Disconnection of service from remote server.

ADVANTAGES

1. From this system consumer can set the monthly electricity billing budget. Hence less wastage of energy.
2. Every month the person from electricity department has not to visit the consumer house for the note down the consumed energy hence labour work get reduced.
3. The cost of this device is not more because the system uses the low cost equipment and also the installed energy meter will not be replaced or tampered. From the installed energy meter authorized this system takes the input.

CONCLUSION

In the area of smart city, smart grid advancement, prototype smart energy meter is a step forward and it mainly focusses on the connectivity & networking factor of the IoT. In this system, an energy consumption calculation based on the counting of calibration pulses is designed and implemented using Arduino Uno MCU in embedded system domain. In the proposed work, IoT based meter reading system is used to continuously monitor the meter reading, current energy consumption, theft detection and service provider can disconnect the power source whenever the consumer does not pay the monthly bill. All these information are sent in the form of message alerts to the consumer mobile phone. Also it eliminates the human intervention, delivers effective meter reading, prevent the billing mistakes.



SRI RAAJA RAAJAN
COLLEGE OF ENGINEERING AND TECHNOLOGY
(Approved by AICTE, New Delhi & Affiliated to Anna University, Chennai)

146/14B1, Amaravathi Village, Amaravathiputhur Post,
Karaikudi – 630 301, Sivagangai Dt, Tamil Nadu

Website : www.srirajaraajan.in, E-mail : srrcet2010@gmail.com, Ph: 04565-234230

**DEPARTMENT OF ELECTRONICS AND
COMMUNICATION ENGINEERING**

INNOVATIVE PROJECT

PATIENT MONITORING SYSTEM



SRI RAAJA RAAJAN
COLLEGE OF ENGINEERING AND TECHNOLOGY
(Approved by AICTE, New Delhi & Affiliated to Anna University, Chennai)

PATIENT MONITORING SYSTEM

Abstract

Global health which denotes equitable access to healthcare, particularly in remote-rural- developing regions, is characterized by unique challenges of affordability, accessibility, and availability for which one of the most promising technological interventions that is emerging is the LED based remote health monitoring. We present an LED based smart edge system for remote health monitoring, in which wearable vital sensors transmit data. We have carried out both clinical validation and performance evaluation of our smart edge system. The clinical validation of patients demonstrated that the LED based monitoring is highly effective in remote monitoring.

INTRODUCTION

A Remote health monitoring system is an extension of a hospital medical system where a patient's vital body state can be monitored remotely. Traditionally the detection systems were only found in hospitals and were characterized by huge and complex circuitry which required high power consumption. Continuous advances in the semiconductor technology industry have led to sensors and microcontrollers that are smaller in size, faster in operation, low in power consumption and affordable in cost.

Statement of the problem:

Remote health monitoring can provide useful physiological information in the home. This monitoring is useful for elderly or chronically ill patients who would like to avoid a long hospital stay. Wireless sensors are used to collect and transmit signals of interest and a processor is programmed to receive and automatically analyze the sensor signals.

In this project, you are to choose appropriate sensors according to what you would like to detect and design algorithms to realize your detection.

Examples are the detection of a fall, monitoring cardiac signals. Using a single parameter monitoring system an approach to a remote health monitoring system was designed that extends healthcare from the traditional clinic or hospital setting to the patient's home.

The system was to collect a heartbeat detection system data, fall detection system data, temperature data and few other parameters. The data from the single parameter monitoring systems was then availed for remote detection.

Purpose of the study

Design a Remote Patient Health Monitoring System (RPHMS) which has heartbeat detection system, a fall detection system, temperature detection system, a humidity detection system, a toxic gas and air quality detection system and SPO2 detection system. A doctor or health specialist can use the system to monitor remotely of all vital health parameters of the patient or person of interest.

An attempt at designing a remote healthcare system made with locally available components.

i) The fall detector, temperature, humidity, pressure, toxic gas, air quality control, SPO2 modules comprise of an accelerometer, wireless transmitter and microcontroller. The data collected was transmitted wirelessly to a receiver module.

ii) ECG consists of a non-invasive infrared finger detector, Liquid Crystal Display (LCD)

iii) designed circuit for cardiac signal detection and microcontroller. The detected analog signal was then digitized to give a digital value that was read on the LCD.

iv) A simple cloud server where hosted with a database for all the vital data to be accessed remotely whenever required.

EXISTING SYSTEM

In the existing system, we use active network technology to network various sensors to a single PMS. Patients' various critical parameters are continuously monitored via single PMS and reported to the Doctors or Nurses in attendance for timely response in case of critical situations.

The sensors are attached to the body of the patients without causing any discomfort to them. In this PMS we monitor the important physical parameters like body temperature, ECG, heart beat rate and blood pressure using the sensors which are readily available.

Thus, the analog values that are sensed by the different sensors are then given to a microcontroller attached to it. The microcontroller processes these analog signal values of health parameters separately and converts it to digital values using ADC converter.

Now, the digitalized values from more than one microcontroller are sent to the Central PMS. Each of the sensors attached microcontroller with a transceiver will act as a module which has its own unique ID.

Each module transmits the data wirelessly to the gateway attached to the PC of the Central PMS. The gateway is attached to the PC i.e. Central PMS which is situated in the medical center, is capable for selecting different patient IDs and allowing the gateway to receive different physical parameter values the patient specified by the ID.

PROPOSED SYSTEM

In this project, three LED modules were interconnected with the Arduino Uno board along with buzzer. When the patient is in emergency, he will press the buzzer.

Alarm will alert the nurse. LED light of that corresponding room will glow and it indicates that the corresponding glowing room is under emergency and it helps the nurse to identify the patient who is under emergency.

LIGHT-EMITTING DIODE

A light-emitting diode (LED) is a semiconductor device that emits light when current flows through it. Electrons in the semiconductor recombine with electron holes, releasing energy in the form of photons. The color of the light (corresponding to the energy of the photons) is determined by the energy required for electrons to cross the band gap of the semiconductor. White light is obtained by using multiple semiconductors or a layer of light-emitting phosphor on the semiconductor device

Appearing as practical electronic components in 1962, the earliest LEDs emitted low intensity infrared (IR) light. Infrared LEDs are used in remote-control circuits, such as those used with a wide variety of consumer electronics. The first visible-light LEDs were of low intensity and limited to red.

LEDs have many advantages over incandescent light sources, including lower power consumption, a longer lifetime, improved physical robustness, smaller sizes, and faster switching. In exchange for these generally favorable attributes, disadvantages of LEDs include electrical limitations to low voltage and generally to DC (not AC) power, the inability to provide steady illumination from a pulsing DC or an AC electrical supply source, and a lesser maximum operating temperature and storage temperature.

BUZZER

A buzzer or beeper is an audio signaling device, which may be mechanical, electromechanical, or piezoelectric (*piezo* for short). Typical uses of buzzers and beepers include alarm devices, timers, train and confirmation of user input such as a mouse click or keystroke.

Piezoelectric

Piezoelectric buzzers, or piezo buzzers, as they are sometimes called, were invented by Japanese manufacturers and fitted into a wide array of products during the 1970s to 1980s. This advancement mainly came about because of cooperative efforts by Japanese manufacturing companies. In 1951, they established the Barium Titanate Application Research Committee, which allowed the companies to be "competitively cooperative" and bring about several piezoelectric innovations and inventions.

ARDUINO

Arduino is an Italian open-source hardware and software company, project, and user community that designs and manufactures single-board microcontrollers and microcontroller kits for building digital devices. Its hardware products are licensed under a CC BY-SA license, while the software is licensed under the GNU Lesser General Public License (LGPL) or the GNU General Public License (GPL) permitting the manufacture of Arduino boards and software distribution by anyone. Arduino boards are available commercially from the official website or through authorized distributors.

Arduino board designs use a variety of microprocessors and controllers. The boards are equipped with sets of digital and analog input/output (I/O) pins that may be interfaced to various expansion boards ('shields') or breadboards (for prototyping) and other circuits. The boards feature serial communications interfaces, including Universal Serial Bus (USB) on some models, which are also used for loading programs. The microcontrollers can be programmed using the C and C++ programming languages (Embedded C), using a standard API which is also known as the Arduino Programming Language, inspired by the Processing language and used with a modified version of the Processing IDE. In addition to using traditional compiler toolchains, the Arduino project provides an integrated development environment (IDE) and a command line tool developed in Go.

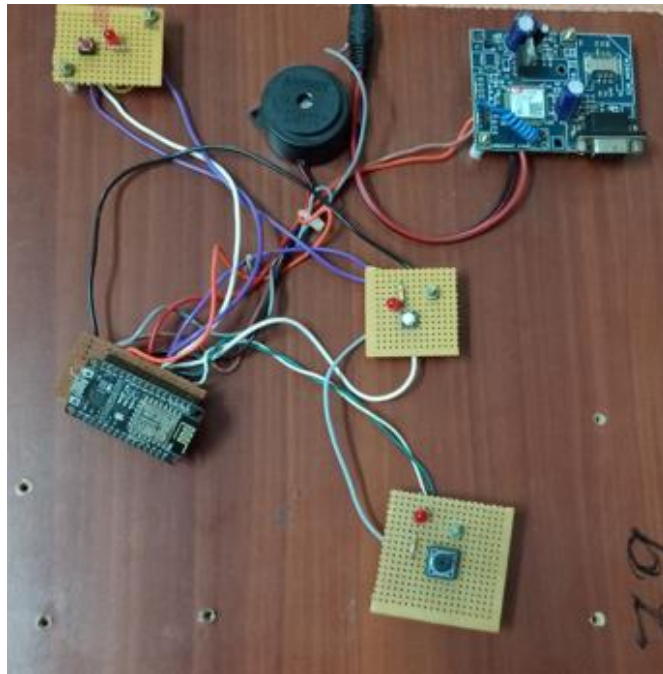

Fig. LED based patient monitoring system

CONCLUSION

In our Project, Patient health was monitored by LED based monitoring system in which, in case of emergencies, the patient will press buzzer in which alarm will alert the nurse who is nearby and also LED will glow in that specific room, Because of that the nurse could identify the room in which the patient has emergency. So the patient was successfully monitored by LED based Patient monitoring system



**SRI RAAJA RAAJAN
COLLEGE OF ENGINEERING AND TECHNOLOGY**

(Approved by AICTE, New Delhi & Affiliated to Anna University, Chennai)

146/14B1, Amaravathi Village, Amaravathiputhur Post,
Karaikudi – 630 301, Sivagangai Dt, Tamil Nadu

Website : www.srirajaraajan.in, E-mail : srrcet2010@gmail.com, Ph: 04565-234230

**DEPARTMENT OF ELECTRONICS AND
COMMUNICATION ENGINEERING**

INNOVATIVE PROJECT

**Automatic Lighting system
using Arduino and PIR
Sensor**



Automatic Lighting system using Arduino and PIR Sensor

Abstract

Automatic Light Controller Using Arduino and PIR Sensor can be used to turn ON and OFF the illumination system of college routinely by sensing the existence of human .” Such Automatic Lights structures may be applied on your Classrooms, college cabins. Where in we do now no longer want steady mild however best whilst people are existing”. Also, with the help of this system, we will shop the electricity invoice as energy can be fed on best whilst human is gift i.e. whilst required lighting fixtures can be spontaneously became ON or OFF. This Project contains Automatic room light using Arduino, PIR sensor and relay module. PIR sensor will detect the movement based totally on reaction of PIR sensor will perform accordingly.

INTRODUCTION

Not only may energy-efficient buildings save costs, but they can also be comfortable and offer lots of natural light. These characteristics make a college's learning atmosphere more favorable. Human comfort has become much more difficult due to mechanical switches, which have also grown neglect. Maximum power loss has been found in these situations, which further reduces productivity and development. One comprehensive approach to combating this kind of carelessness is to work toward automating power control. It has been noted that most air conditioners and lighting systems are neglected by students or lecturers after classes, which results in wasted electricity in colleges. Building an automation system is becoming more and more necessary for homes and offices due to its many advantages.

Efficient and cost-effective automated systems for monitoring and managing various appliances such as air conditioners, fans, lighting, and other devices are being developed by researchers and industrialists. Automation guarantees effective utilization and low electricity loss.

Reduced energy use is necessary due to rising energy costs. In educational facilities like lecture halls and rooms, a substantial quantity of energy is consumed for lighting and air conditioning. Thus, in order to prevent wasting energy during empty hours, modifications are required.

To cut expenses, demand-based controls for the lighting and air conditioning will be used. A lecture hall, school, laboratory, or resident hall might all need an energy control system. Among the essential energies in modern human life is electricity. Most customers are unaware of the significance of lowering the cost of energy, therefore investments in controlling and conserving this resource are necessary due to rising costs associated with production and delivery as well as rising demand. Because of this requirement, an Arduino board and a motion sensor were used to detect human body heat in order to build this energy-saving project. When the sensor finds nobody is in any of the

classrooms or lecture halls, the arduino will calculate to a predefined time, say 10 minutes. The air conditioning and lighting systems will automatically reset if any students enter the lecture hall during this period. Nevertheless, the air conditioner and lighting will automatically shut off if the hallway remains unoccupied.

Circuit Diagram of Automatic Lighting system using Arduino

The following image shows the circuit diagram of the project implemented using Arduino UNO, PIR Sensor and a Relay Module.

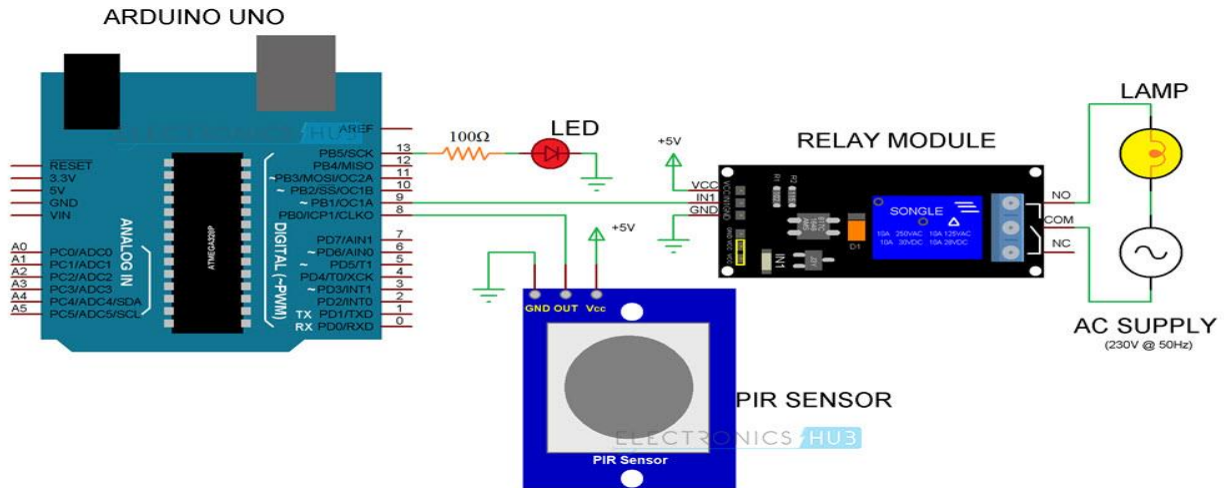

BLOCK DIAGRAM 1

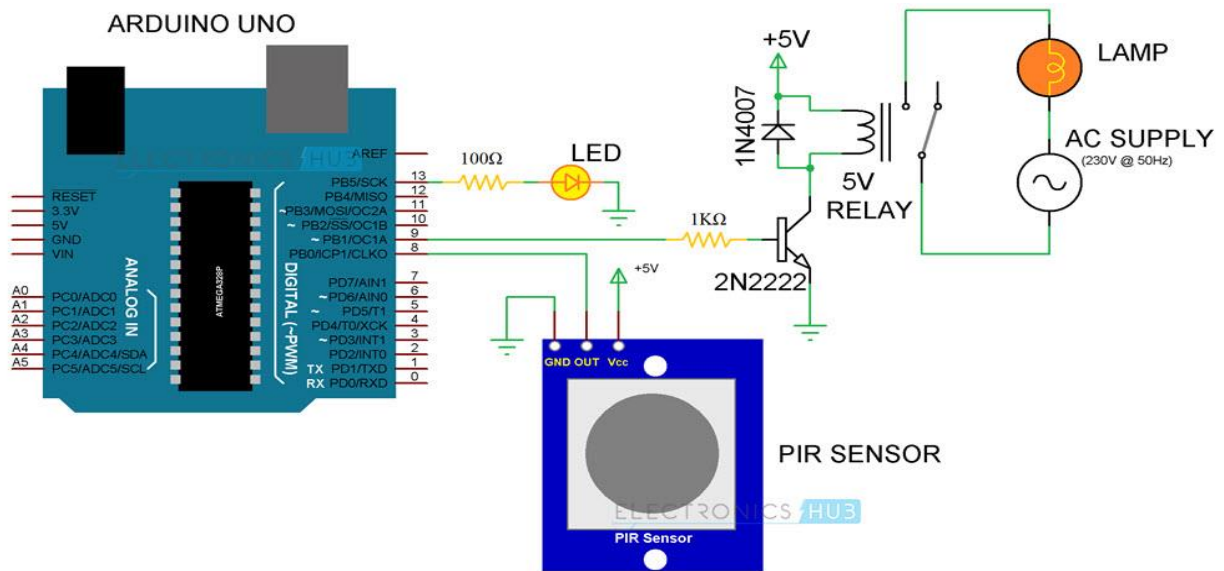

BLOCK DIAGRAM 2

Components Required for Automatic Lights using Arduino

- Arduino UNO
- PIR Sensor
- 5V Relay Module (Relay Board)
- LED
- 100 Ω Resistor (1/4 Watt)
- Connecting Wires
- Breadboard
- Power Supply

If you do not have a Relay Module, use the following components:

- 5V Relay
- 2N2222 (or BC547) NPN Transistor
- 1N4007 PN Junction Diode
- 1K Ω Resistor (1/4 Watt)

Hardware Detail

Arduino Uno

Based on the ATmega328P microprocessor, the Arduino Uno is an open-source microcontroller board. A reset button, a power jack, an ICSP header, six analog inputs, a USB port, and fourteen digital I/O pins are all included. All the modules required to support the microcontroller are included in it. Simply use a USB cable to connect it to a computer, or an adapter to supply power, to begin going. Without giving it too much thought, you can explore with your Arduino.



Figure 3.Arduino Uno

Arduino UNO Board Layout

A typical Arduino UNO board's layout is seen in the following figure. Every component is positioned on the PCB's top side.

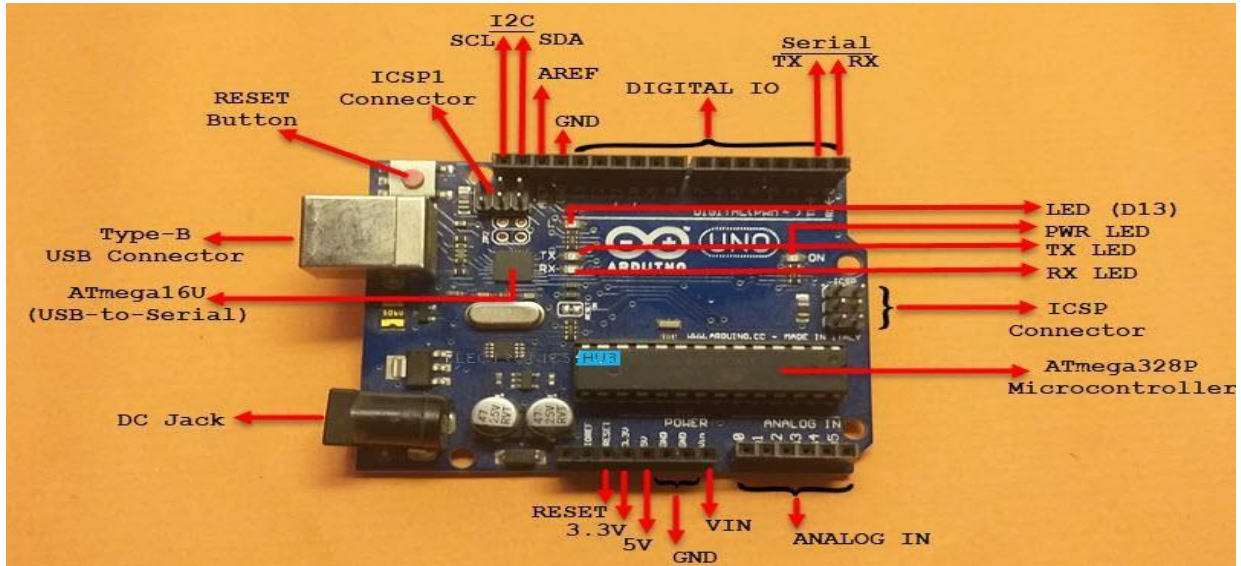

Figure 4. Arduino Unoboard layout

A Type-B USB connector, which is used to power on the board and program the microcontroller, is visible on the left short edge of the board. To supply an external power source, there is also a 2.1 mm DC jack.

Technical Specifications of Arduino UNO

Given that the Arduino UNO is built around the ATmega328P microcontroller, the majority of its technical specs pertain to the ATmega328P MCU. However, allow me to provide you with a quick rundown of some of the most crucial Arduino UNO specs.

MCU	ATmega328P
Architecture	AVR
Operating Voltage	5V
Input Voltage	6V – 20V (limit) 7V – 12V (recommended)
Clock Speed	16 MHz
Flash Memory	32 KB (2 KB of this used by bootloader)
SRAM	2 KB
EEPROM	1 KB
Digital IO Pins	24 (of which 6 can produce PWM)
Analog Input Pins	6

Power up the Arduino UNO

There are two methods for providing power to the UNO board. Using a Type-B USB connector is the first and easiest method. The second method involves giving the UNO's VIN pin (Pin number 26) an uncontrolled supply between 6 and 20 volts.

Alternatively, the 2.1mm DC Jack can be used to supply an unregulated supply; in this instance, the VIN Pin can be used to access the supplied voltage.

Different Memories of Arduino UNO

This is exclusive to the Arduino UNO Board's chosen microcontroller, the ATmega328P. Atmel ATmega328P has access to three distinct memory types. They're:

- 32 KB of FLASH MEMORY
- Two kilobytes of SRAM
- One kilobyte of EEPROM
- The boot loader code uses 0.5 KB of the Flash Memory.

Input and Output Pins of Arduino UNO

Input and output are connected to 22 of the 32 pins on the UNO board. True digital input/output (D0–D13) pins are those 14 pins. You can use the `pinMode()`, `digitalWrite()`, and `digitalRead()` functions to configure these pins to your application's specifications.

- The highest permissible current for any of these Digital IO pins is 40mA, and they can all source or sink 20mA of current. An extra feature of the Digital IO pins is the availability of internal pull-up resistor (which is not attached by default).
- The internal pull-up resistor will have a value between 20K Ω and 50K Ω .
- Additionally, six analog input pins (A0 to A5) are present. The `analogRead()` function may be used to read the 10-bit resolution ADC feature that is provided by all of the analog input pins.
- The ability of analog input pins to be set up as digital input pins as needed is a key feature.
- 8-bit PWM signals can be generated using Digital IO pins 3, 5, 6, 9, 10, and 11. The `analogWrite()` function is useful in this situation.

Communication Interfaces are available on Arduino UNO

Three different kinds of communication interfaces are supported by the Arduino UNO. They are as follows:

- Serial

- I2C or I2C
- SPI

The Serial Communication interface is arguably the most widely used one in the Arduino community. Indeed, serial connection is used to program the Arduino boards (UNO, Nano, and Mega).

To receive and send serial data, digital IO pins 0 and 1 are utilized as serial RX and TX pins. These pins are linked to the on-board USB to Serial Converter IC's serial pins.

Pins A4 and A5 on the analog input have different purposes. They can be set up to handle Two Wire Interface (TWI) or I2C or SDA (A4) and SCL (A5) communication.

The SPI is the last interface for communication. SPI pins SS, MOSI, MISO, and SCK, respectively, can be set for Digital IO Pins 10, 11, 12, and 13.

BC547 Transistor

Regarding the triode type, BC547 is fundamentally believed to be a normal NPN (Negative-Positive-Negative) junction transistor. Furthermore essential to comprehending the foundations of the BC547 are the pin diagram and the BC547 parameter. I will go over the new electronic component, BC547, below. Often used when quick switching is needed, this BJT transistor I suggest downloading BC547 Proteus Simulation if you intend to use this transistor in an engineering project. It is usually a better idea to simulate before entering the hardware, as we all know. Now, let us investigate the basic knowledge of BC547.

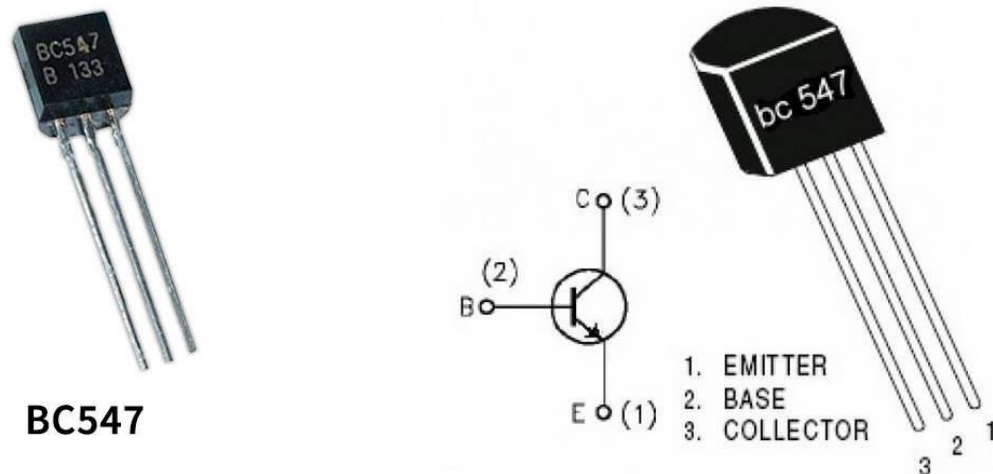

100uF 25V Capacitor

A capacitor can be used to store, filter, or smooth off electrical charge in many situations when working with electronic circuits. To lessen the effects of surges, ripples, and abrupt decreases in current, a 100 μ F 25V electrolytic capacitor is perfect for low frequency communications during such

periods. These variations in current are captured, managed, and capable of producing a steady, reliable current with a capacitor to maintain the smooth operation of your projects.

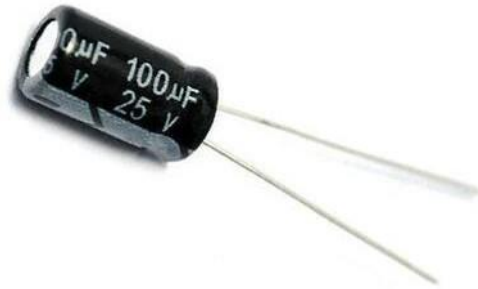

LED (Light Emitting Diode)

Light-emitting diodes are the source of light in LED light bulbs and lamps. Being a "solid-state" technology, LEDs use components that are enclosed in solid materials to produce light. According to practical calculations, this means a lamp with a rated life significantly longer than those that use non-solid-state technology (such as fluorescent, halogen, and incandescent lighting). Moreover, shock and vibration-related lighting failures are far less common with solid-state lighting.



HC-SR501 PIR Motion Sensor

Highly adaptable, the HC-SR501 sensor is frequently found in motion-sensitive devices such as security systems, automated lighting, and others. HC-SR501 can function in a wide variety of temperatures and across long distances, depending on how it is configured.

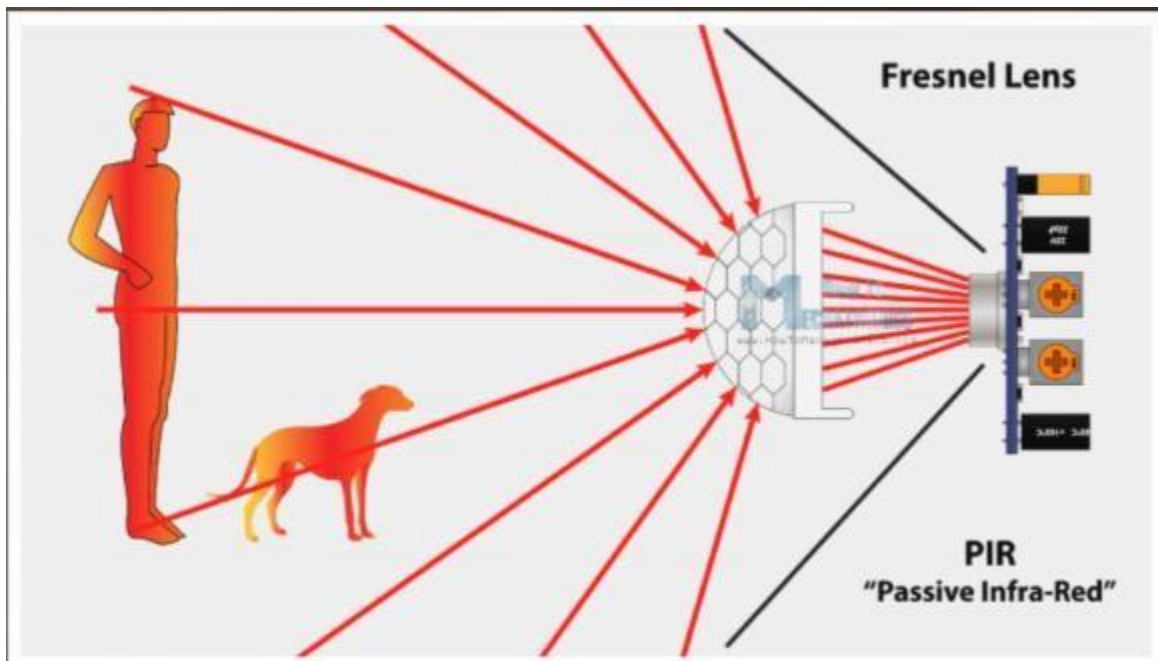
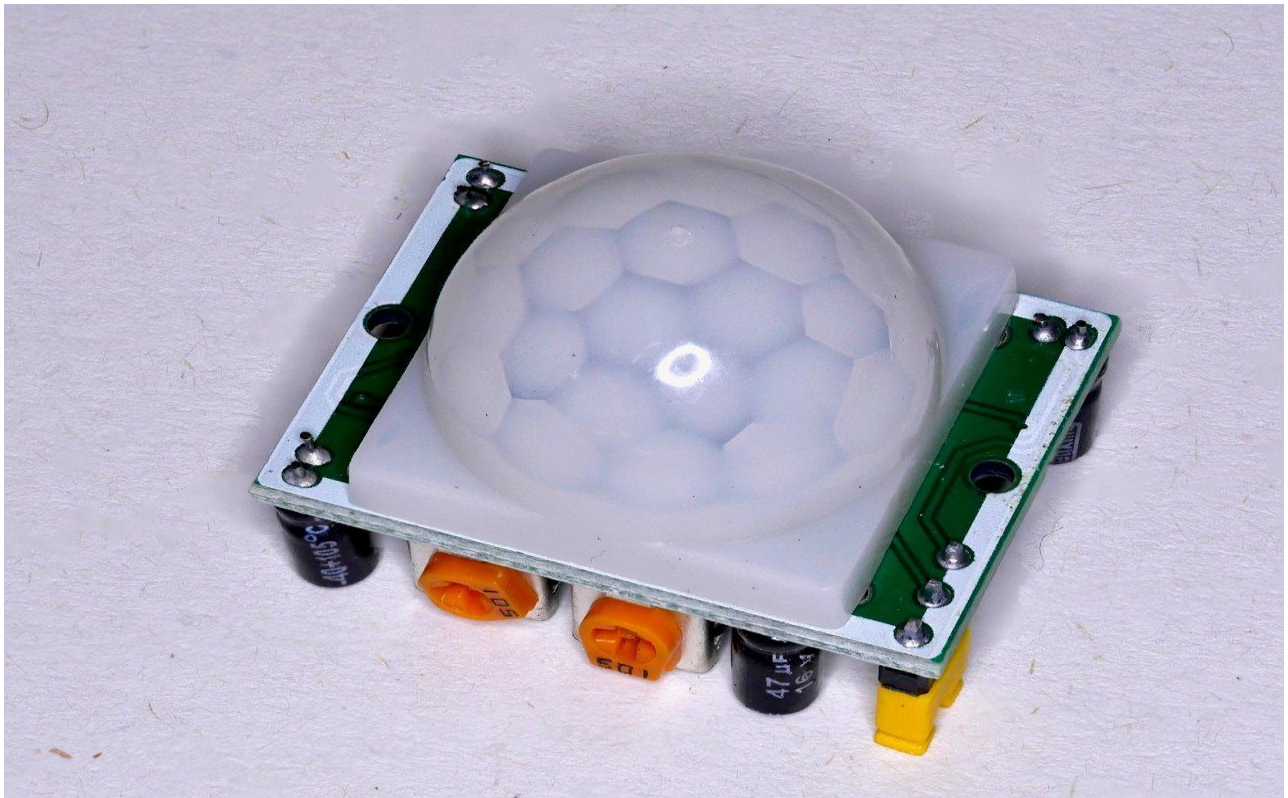

HC-SR501 Motion Sensor Work

In order to comprehend its workings, it is necessary to gain a better understanding of PIR, or passive infrared, the technology at the heart of it. To put it simply, infrared radiation is the radiant energy that heated objects can emit; it has various wavelengths or frequencies and is not visible to the human eye, though it can be felt by humans. Burning coal is a prime example of this; while the smoke is usually invisible, it is still hot.

As waves enter an object through the atmosphere, they react by producing infrared radiation. As a result of their excitation of the molecules within the objects, heat is produced. As it happens, infrared is also produced by warm bodies—human and animal alike. HC-SR501 and similar devices utilize this heat to identify variations in infrared, potentially indicating the presence of a moving body.

Code

The code for the Automatic Lights using Arduino and PIR Sensor is given below.

```
int in1 = 9;
int sensor = 8;
int led = 13;
unsigned long t=0;
void setup()
{
  Serial.begin(9600);
  pinMode(in1, OUTPUT);
  pinMode(sensor, INPUT);
  pinMode(led, OUTPUT);

  digitalWrite(in1,HIGH);
  digitalWrite(led,LOW);
  while(millis())<13000)
  {
    digitalWrite(led,HIGH);
    delay(50);
    digitalWrite(led,LOW);
```

```

    delay(50);
}
digitalWrite(led,LOW);

}
void loop()
{
    digitalWrite(in1,HIGH);
    digitalWrite(led,LOW);
    if(digitalRead(sensor)==HIGH)
    {
        t=millis();
        while(millis()<(t+5000))
        {
            digitalWrite(in1,LOW);
            digitalWrite(led,HIGH);
            if((millis())>(t+2300))&&(digitalRead(sensor)==HIGH)
            {
                t=millis();
            }
        }
    }
}
}

```

Working of the Project

The Automatic Room Lights using Arduino and PIR Sensor is a simple project, where the lights in the room will automatically turn on upon detecting a human motion and stay turned on until the person has left or there is no motion.

Initially, when there is no human movement, the PIR Sensor doesn't detect any person and its OUT pin stays LOW. As the person enters the room, the change in infrared radiation in the room is detected by the PIR Sensor.

As a result, the output of the PIR Sensor becomes HIGH. Since the Data OUT of the PIR Sensor is connected to Digital Pin 8 of Arduino, whenever it becomes HIGH, Arduino will activate the relay by making the relay pin LOW (as the relay module is an active LOW module).

APPLICATION

The Motion Sensor Light Switch utilizing an Infrared (PIR) sensor presents a myriad of applications across various domains, offering enhanced convenience, energy efficiency, and automation. The versatility of this technology lends itself to a range of practical uses:

1. Residential Lighting Control:
2. Energy-Efficient Commercial Spaces:
3. Security Lighting:
4. Smart Home Integration:
5. Industrial Environments:
6. Public Spaces and Facilities:
7. Adaptive Street Lighting:

Results

The implementation of the Motion Sensor Light Switch with a Passive Infrared (PIR) sensor has delivered promising results, showcasing seamless integration of hardware and programming for desired functionality. Key outcomes from testing and evaluation include:

1. Motion Detection Accuracy: The PIR sensor demonstrated exceptional accuracy in detecting human motion, with sensitivity adjustments ensuring consistent and reliable detection.
2. Reliability of Relay Module: The relay module consistently controlled the electrical circuit of the light source, responding precisely to the PIR sensor's input.
3. Real-time Responsiveness: The system showed real-time responsiveness to detected motion, enhancing the practicality of the motion sensor light switch.
4. Stability and Equilibrium: The self-balancing feature contributed to system stability, ensuring reliable and safe operation during motion detection and light activation.
5. User-Friendly Operation: The user interface, whether manual or automated, proved intuitive, enhancing the overall user experience and accessibility.
6. Energy Efficiency: The project effectively optimized energy consumption by activating the light source only in response to detected motion.

7. **Versatility and Adaptability:** The modular design showcased versatility and adaptability, allowing for future enhancements and modifications.
8. **Scalability for Smart Home Integration:** The project demonstrated scalability for integration into broader smart home ecosystems, evolving with advancements in home automation.
9. **Cost-Effectiveness:** Leveraging commercial components enhanced cost-effectiveness, making the technology accessible to a diverse user base.

In summary, the results indicate a successful implementation meeting objectives of reliable motion detection, responsive light control, and energy efficiency. These outcomes provide a solid foundation for further development, optimization, and integration into larger smart home systems.

CONCLUSION

In conclusion, the Motion Sensor Light Switch project, utilizing a Passive Infrared (PIR) sensor, signifies a pioneering blend of technology and practicality in home automation. The integration of PIR sensor, relay module, and Arduino showcases a streamlined yet highly effective method for creating an intelligent lighting system responsive to human presence, promoting energy efficiency and user convenience.

The project's success lies in its accessibility, utilizing readily available commercial components for ease of maintenance and cost-effectiveness, making the technology viable for a diverse user base. Looking ahead, promising prospects include deeper integration with smart home platforms, enabling seamless control through voice commands and remote applications. Commitment to sustainability could be enhanced through advanced technologies like machine learning, adapting the system based on user behavior and historical data.

Security enhancements present an opportunity for expansion, transforming the project into a comprehensive solution with additional sensors for intrusion detection, contributing significantly to overall home security. Ultimately, the Motion Sensor Light Switch project serves as an exemplary model of innovation and practicality, emphasizing balance in delivering user-centric advantages. As technology progresses, this project provides a robust foundation for future developments, influencing the trajectory of smart home automation with its simplicity, adaptability, and potential for further customization.



**SRI RAAJA RAAJAN
COLLEGE OF ENGINEERING AND TECHNOLOGY**

(Approved by AICTE, New Delhi & Affiliated to Anna University, Chennai)

146/14B1, Amaravathi Village, Amaravathiputhur Post,
Karaikudi – 630 301, Sivagangai Dt, Tamil Nadu

Website : www.srirajaraajan.in, E-mail : srrcet2010@gmail.com, Ph: 04565-234230

**DEPARTMENT OF ELECTRONICS AND COMMUNICATION
ENGINEERING**

INNOVATIVE PROJECT

**RFID BASED SMART TRANSPORTATION SYSTEM USING
GSM AND GPS TECHNOLOGY**



SRI RAAJA RAAJAN
COLLEGE OF ENGINEERING AND TECHNOLOGY
(Approved by AICTE, New Delhi & Affiliated to Anna University, Chennai)

RFID BASED SMART TRANSPORTATION SYSTEM USING GSM AND GPS TECHNOLOGY

ABSTRACT

Now a days, a bus tracking system has been widely used for fleet (group of buses) management and asset tracking. GPS and RFID Based Intelligent Bus Tracking System is useful, accurate, robust, flexible and economical. In this work, GPS is used for obtaining the location of the bus using Google Map and RFID is used for the identification of bus. RFID card is also used here for transactions related to fuel filling. Therefore, whole information of a particular bus is stored in database at the server side. An ultimate aim of this system is to develop a flexible, cost effective and user-friendly vehicle tracking system that can cater the needs of owner of transportation companies with minimum technologies backing at the user end. In developing countries, such technologies are very useful for tracking of vehicles.

INTRODUCTION

Today, the fundamental support for global economy of many industries is the transportation of people, goods, and services. The owner of transportation networks no longer see the actual movement of bus, but the owner expects a certain quality of service in terms of the safety assurance, journey time, facilities provided during travel. Vehicular tracking systems has proved to be as a useful technology for bus traveler agencies with good facilities. Bus information taken care with RFID and existing location taken care with GPS.

Current tracking processes that are in use, such as barcode scanning software, in situations where hundreds of bus are present, the act of scanning each individual bus to check for proper placement can become a tedious and inefficient use of company time and energy. With the design and implementation of an vehicle monitoring system, we are able to drastically reduce the effort needed to monitor and track a large number of target vehicles. This prototype, when

implemented, will allow for a more efficient vehicle tracking system that saves time and, in the end, saves money while providing a simpler tracking device. Using active RFID hardware and a medium strength RFID receiver, we designed a prototype tracking unit to be used to solve the issues surrounding large scale vehicle monitoring. The prototype combines the capabilities of the RFID receiver with a GPS tracking unit and an onboard embedded device to provide a complete base unit capable of tracking, monitoring, and saving vehicle information within one device. A successful and complete prototype was designed and implemented over the course of this project. The prototype properly tracks any number of target vehicles through RFID tag scanning and GPS location checking, entered vehicle information. Individual bus details can be accessed by the user through various menus that are provided during the running of the program. This will allow the prototype to be adapted to many different areas of use, instead of a predetermined work environment.

GLOBAL POSITIONING SYSTEM (GPS)

The Global Positioning System (GPS) is a space based navigation system that provides location in all weather conditions. GPS satellites continuously transmit their current time and position. A GPS receiver monitors multiple satellites and solves equations to determine the exact position of the receiver and its deviation from true time. At a minimum, four satellites must be in view of the receiver for it to compute four unknown quantities (three position coordinates and clock deviation from satellite time).

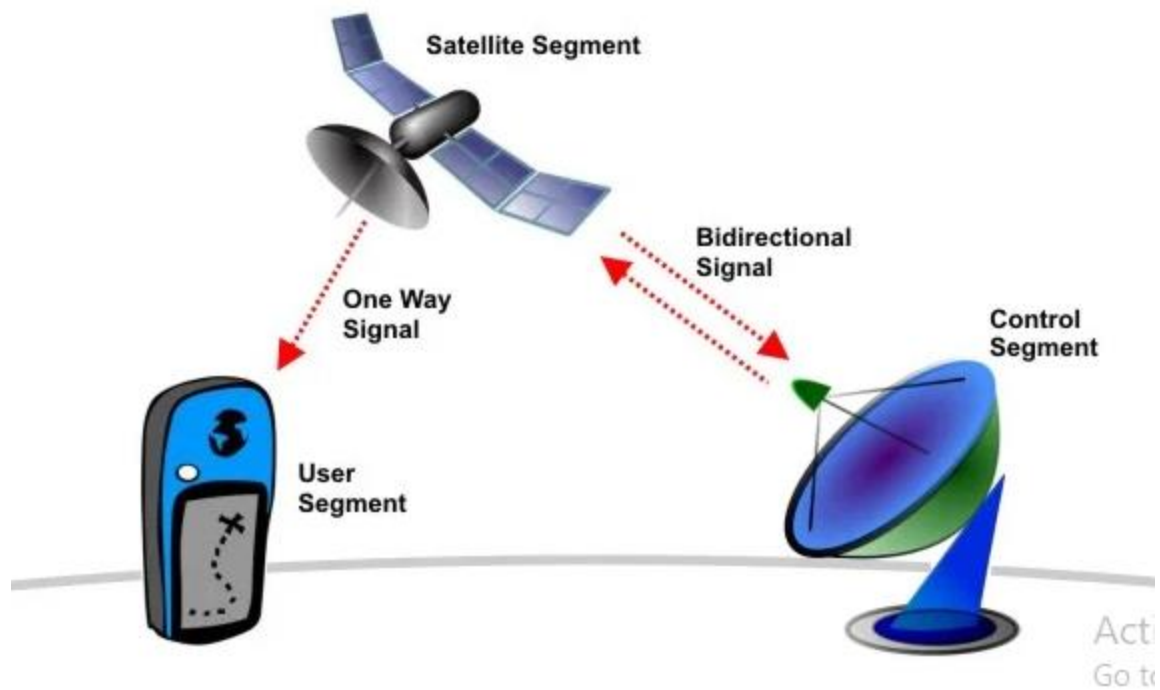

RADIO FREQUENCY IDENTIFICATION (RFID)

A radio-frequency identification system uses tags, or labels attached to the objects to be identified. Two-way radio transmitter-receivers called interrogators or readers send a signal to the tag and read its response. RFID tags can be either passive or active. Passive tags collect energy from a nearby RFID reader's interrogating radio waves.

Basic RFID System

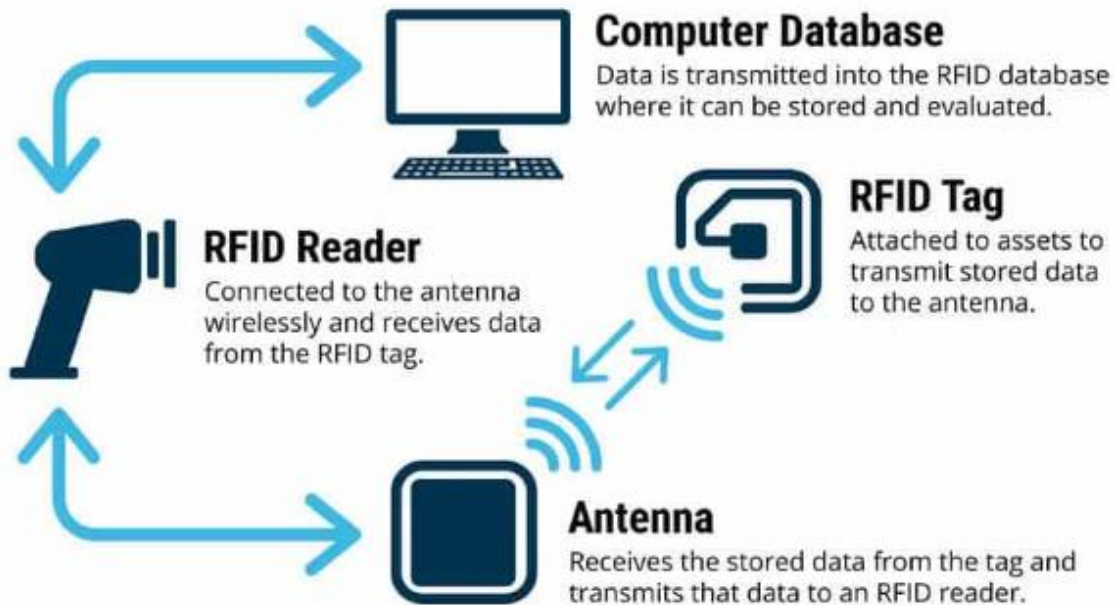

PROPOSED METHOD

Many researchers have contributed to the development of Intelligent transportation system (ITS) for various applications like vehicle position tracking systems, vehicle anti-theft tracking systems, Bus Tracking system and fleet management systems. These applications are intended to track the system with respect to the workstation PC and Smartphone. Authors in demonstrate VERTIGUO (Vehicular Tracking Using Open source approach), a GPS, GSM and GPRS technology based vehicular tracking system. Authors in demonstrate an SMS based vehicle tracking system to transfer the latitude, longitude from GPS and automobile data to end systems and map their exact location in Google Earth using Keyhole Mark-up Language(KML). Researchers have also worked on SMS tracking system with theft identification and lock feature. An intelligent vehicle tracking system (IVTS) is generally used for tracking and navigation of vehicles. These tracking as well as navigation are possible by using GPS in p-ISSN: 2395-0072 zigbee RFID transmitter, RFID reader module and RFID tag and Relay. This transmitter will be kept on the bus and transmits the data to the receiver. Tracking provides a continuous track of the vehicle whereas Navigation guides the user to the desired destination. The Real Time Bus Monitoring and Passenger Information bus tracking device is a standalone system designed to

display the real-time locations of the buses in metropolitan city. This system will enable the tracking device to obtain GPS data of the bus locations, which will then be transferred to a centralized control unit by using GSM and then transmitted to a bus stop and displayed on the GLCD as per the passenger's request. For bus positioning in real time, in-vehicle unit and a tracking server GSM is used. For this, tracking server also has GSM modem that receives vehicle location information stores this information in database. Four functions have been realized in this management system, such as system personnel management, vehicles management, vehicle information management, and freights information registration and inquiry. The distribution of system personnel authority and the registration and inquiry of the in-and-out vehicles & cargo information have been achieved in this management system, thereby enhanced the efficiency of the current vehicles and security, and promoted a more effective flow of goods.

HARDWARE

The hardware part consists of Transmitter and Receiver. Transmitter is placed on the respective bus and receiver is on the administrator's side. The transmitter will transmits the values of position of the bus via GPS technology and also it transmits the value of RFID tag which will be scan by our RFID reader i.e. placed on our transmitter. Both GPS device as well as RFID tag transmits the alphanumeric values. The respective information which is sent by the transmitter is received by the receiver, receiver collects this information and with the help of software part all the required output will be shown on the screen.

Transmitter

A Transmitter consists of various modules like GPS module, zigbee RFID transmitter, RFID reader module and RFID tag and Relay. This transmitter will be kept on the bus and transmits the data to the receiver.



Fig. Transmitter

GPS MODULE

A GPS is made up of constellation of satellites orbiting around Earth. Each satellite has a atomic clock on its board, so it knows the precise time. As it is orbiting around the Earth, each satellite is continuously transmitting its location at 1.575 GHz. With the help of GPS receiver pointing at the sky, we can listen to these transmissions. When listening to 3 or more satellites transmissions, we can triangulate our location on earth. Finally, with the help of the GPS receiver we could find the following:

- Location
- Latitude and Longitude

RFID TRANSMITTER MODULE

This module includes some subcomponents such as: RFID module(sender) which is used to transmit data from transmitter at bus to receiver at server side. The reasons for using Zigbee RFID are that :

- It requires less power of 3.3V
- It is secured.
- It provides free frequency 2.4GHz
- It produces its own Personal Area Network

A 12V battery is connected to this module through which an Alternate Current (AC) is supplied. This AC is converted to Direct Current (DC) with the help of p-n junction diode and this Direct Current is pulsating. To convert this pulsating DC to smooth DC we have used capacitor filters. The whole current flowing throughout the circuit taken care with resistors. Voltage Regulator is used to provide power of 3.3V to RFID module (sender). The LEDs are used to indicate the various states of system. One is for showing Zigbee power, one is for showing connecting range and one is for indicating sending or receiving.

RFID READER MODULE AND RFID TAG

The system is based on Radio Frequency Identification (RFID) technology and consists of a passive RFID tag. The passive micro information about the Tag ID and sends this information to the base station. The base station receives, decodes transponder tag collects power from the 125 KHz magnetic field generated by the base station, gathers and checks the information available in its Database and used to send those information. The system performed as desired with a 10cm diameter antenna attached to the transponder. RFID Reader Module, are also called as interrogators. They convert radio waves returned from the RFID tag into a form that can be passed on to Controllers, which can make use of it. RFID tags and readers have to be tuned to the same frequency in order to communicate. RFID systems use many different frequencies, but the most common and widely used Reader frequency is 125 KHz.

RELAY

Relay is used to toggle sending of GPS data and RFID data automatically. When the bus is in motion the GPS receiver sends the values to relay and relay forward these values to Receiver and when the us is not in motion and the RFID tag is scanned on RFID reader, it sends the RFID data to relay. Relay forwards this data to receiver for further processing.

RECEIVER

Receiver consists of various modules like zigbee RFID Receiver and Step-down transformer. Receiver will be at the server side where all data transmitted by transmitter will be received and location is found with the help of software.



Fig. Receiver

CONCLUSION

This paper mainly studied the overall design of bus management system based on multi-node RFID cards and GPS. In this work we have developed - the autonomous informative services for bus route map that is flexible, affordable, customizable and accurate. Through this technology, we enable travel agent to track information about their transportation service. We have also demonstrated the credibility of the design through field trials and the initial results obtained through our prototype are very promising. but the advent of this technology, it would make more sense for commuters to know the current location of bus and expected time of arrival and also delay if any before coming to bus stop or while standing at bus stop without having to depend on display system and this has been the major contribution of our research.